



Quick Start Guide

THOR & X

Congratulations on purchasing your THOR
Read this guide to get started to installing and setting your lighting

THOR overview

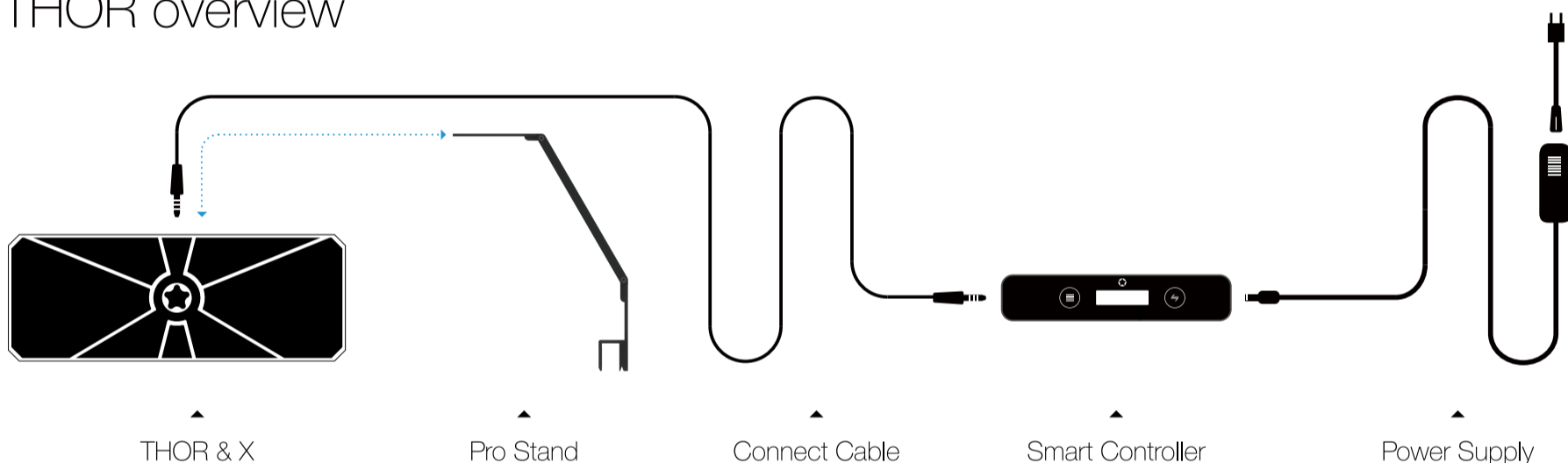

How to install the Pro Stand

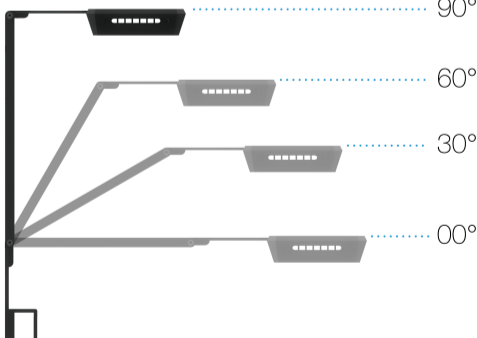
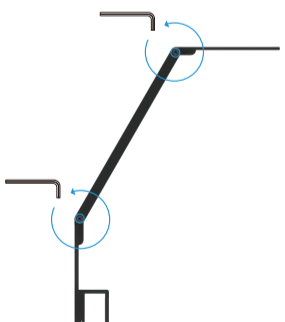
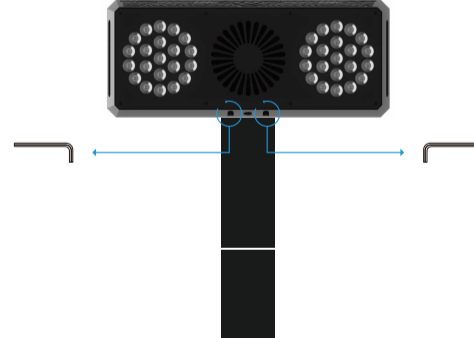
- 1 There are 4 angles choosable, Make sure the gear is coincide.

- 2 Adjust the angle and locked it.

- 3 Lock the THOR to the Pro Stand.

How to install the Hanging Kits

- 1 Assembly hanging kits

- 2 Lock the THOR to the hanging bracket

- 3 Fix to the ceiling



Smart Controller Setup

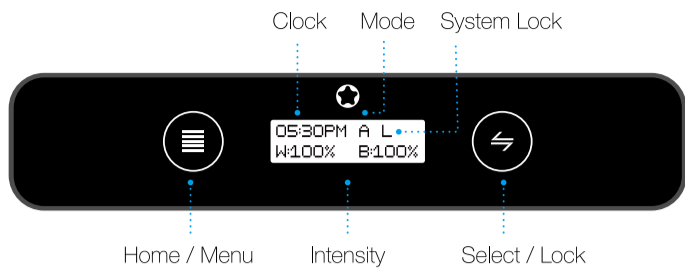

Home / Menu - Browse menu.
 Special Function 1 : Hold on 3 second to return to the previous menu.
 Special Function 2 : Hold on 3 second under locked to switch Auto & Manual mode.

Select / Adjust - Enter the sub-menu to adjust the parameters.
 Special Function 1: Hold on 3 second to unlock system.
 Special Function 2: Hold on 3 second to lock system.

	Auto Mode		Manual Mode	
Systems Loading IMOS 3.0M	05:30PM A L W:100% B:100%	05:30PM A LT S:030%	05:30PM M L W:100% B:100%	05:30PM M LT S:100%
Boot screen	Home screen 1	Home screen 2	Home screen 1	Home screen 2

Note: "A" = Auto Mode, "M" = Manual Mode, "L" = Locked, "LT" = Lightning ON.

Setting up your Light now

1) Set Clock

- Hold Select/Lock for 3 seconds to unlock controller
- Press Home/Menu to enter main menu
- Press Home/Menu to toggle through options
- Press Select/Lock to select 1) Set Clock menu
- Press Select/Lock to adjust time.
- Press Home/Menu to toggle through options
- Press Home/Menu to return to main menu

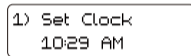

2) Auto Mode - Set LEDs (e.g: Set White Channel)

- Hold Select/Lock for 3 seconds to unlock controller
- Press Home/Menu to enter main menu
- Press Home/Menu to toggle through options
- Press Select/Lock to select 2) Auto Mode menu
- Press Select/Lock to select Set White menu
- Press Select/Lock to adjust Dawn time.
- Press Home/Menu to toggle through options
- Press Home/Menu to select Intensity
- Press Select/Lock to adjust Intensity.
- Press Home/Menu to toggle through options
- Press Home/Menu to move to next setpoint
- Repeat Steps 5-9 for Sunrise, Midday, Sunset, Dusk and Night
- Press Home/Menu to return to main menu

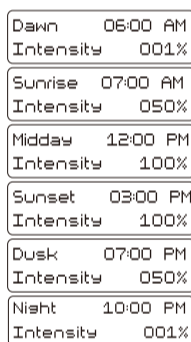

Auto Mode (Set Blue & Special Channel)

Set the Blue Channel and Special Channel which is same as the White Channel operate step.



3) Manual Mode

- Press Select/Lock to select 3) Manual Mode menu
- Press Home/Menu to adjust Enable Manual Mode > Yes/No
- Press Select/Lock to enter the channel selection list
- Press Home/Menu to select the White, Blue, Special Channel
- Press Select/Lock to adjust Intensity for each channel
- Press Home/Menu to return to main menu

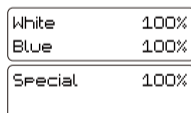
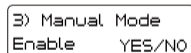

4) Lightning

The advanced settings allow you to control the time period storms will occur in a 24 hour period, the number of storms during this set time and the frequency at which a storm period is activated.

- Hold Select/Lock for 3 seconds to unlock controller
- Press Home/Menu to enter main menu
- Press Home/Menu to toggle through options
- Press Select/Lock to select 5) Set Lightning menu
- Press Select/Lock to adjust Enable Lightning > Yes/No
- Press Home/Menu to set Start/End Hour
- Press Select/Lock to adjust Start/End Hour.
- Press Home/Menu to enter next menu
- Press Home/Menu to set Per Day and Frequency
- Press Select/Lock to adjust Per Day
- Press Home/Menu to set Frequency
- Press Select/Lock to adjust Frequency
- Press Home/Menu to return to main menu

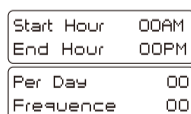

5) Demo

- Press Home/Menu button to enter main menu
 - Press Home/Menu button to select 5) DEMO
 - Press Select/Lock button to select YES
- Note: The DEMO will show all your settings in 1 minute.

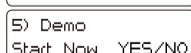
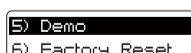

6) Factory Reset

- Press Home/Menu button to enter main menu
- Press Home/Menu button to select 6) Factory Reset
- Press Select/Lock button to select YES
- Press Home/Menu button to set Factory Reset

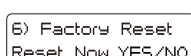

The Control system will gradually ramp the intensity of LED between set points. The graph below outlines how the LEDs will ramp up and down between settings.

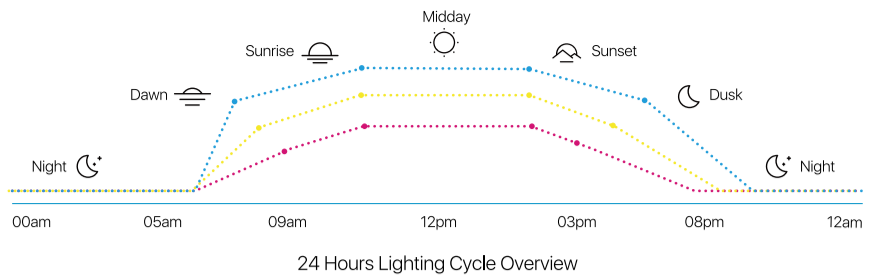

The sample settings below can be used to create different color spectrums in your tank.

10K White for Fish Tank						
	Dawn	Sunrise	Midday	Sunset	Dusk	Night
White ChannelA	0% @ 6:00AM	80% @ 8:00 AM	100% @ 12:00 PM	100% @ 3:00 PM	80% @ 6:00 PM	0% @ 8:00 PM
Blue ChannelB	0% @ 6:00AM	25% @ 7:00 AM	50% @ 10:00 AM	50% @ 3:00 PM	25% @ 6:00 PM	0% @ 8:00 PM
Special ChannelC	0% @ 6:00AM	50% @ 8:00 AM	75% @ 12:00 PM	75% @ 3:00 PM	50% @ 6:00 PM	0% @ 8:00 PM

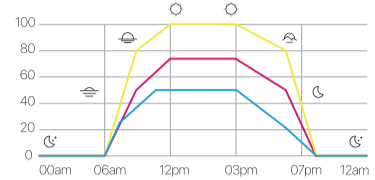

15K White & Blue for LPS						
	Dawn	Sunrise	Midday	Sunset	Dusk	Night
White ChannelA	0% @ 6:00AM	50% @ 8:00 AM	100% @ 12:00 PM	100% @ 2:00 PM	50% @ 6:00 PM	0% @ 8:00 PM
Blue ChannelB	1% @ 6:00AM	80% @ 7:00 AM	100% @ 10:00 AM	100% @ 2:00 PM	80% @ 6:00 PM	1% @ 8:00 PM
Special ChannelC	0% @ 6:00AM	50% @ 8:00 AM	75% @ 12:00 PM	75% @ 3:00 PM	50% @ 6:00 PM	0% @ 8:00 PM

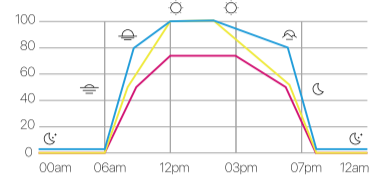

20K Heavy Blue for SPS						
	Dawn	Sunrise	Midday	Sunset	Dusk	Night
White ChannelA	0% @ 6:00AM	25% @ 8:00 AM	50% @ 12:00 PM	50% @ 3:00 PM	25% @ 6:00 PM	0% @ 8:00 PM
Blue ChannelB	1% @ 6:00AM	80% @ 7:00 AM	100% @ 10:00 AM	100% @ 3:00 PM	80% @ 6:00 PM	1% @ 8:00 PM
Special ChannelC	0% @ 6:00AM	50% @ 8:00 AM	75% @ 12:00 PM	75% @ 3:00 PM	50% @ 6:00 PM	0% @ 8:00 PM

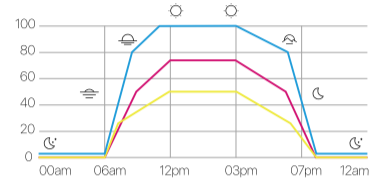

7000K White for Planted						
	Dawn	Sunrise	Midday	Sunset	Dusk	Night
W-White ChannelA	0% @ 6:00AM	25% @ 8:00 AM	50% @ 12:00 PM	50% @ 3:00 PM	25% @ 6:00 PM	0% @ 8:00 PM
White ChannelB	0% @ 6:00AM	80% @ 7:00 AM	100% @ 10:00 AM	100% @ 3:00 PM	80% @ 6:00 PM	0% @ 8:00 PM
Special ChannelC	0% @ 6:00AM	50% @ 8:00 AM	75% @ 12:00 PM	75% @ 3:00 PM	50% @ 6:00 PM	0% @ 8:00 PM

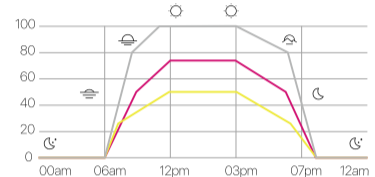

Information

ATTENTION: Never put the light and the smart controller in the water. Doing so will be dangerous and damage your light.

WARNING: Do not touch the lights body when it is working which will generate heat and may let your hands be uncomfortable.

WARNING: Make sure all the cables are connected before plug to electricity or will damage your light.

Important Handling Information

NOTICE: Failure to follow these handling instructions could result in damage to your Light or other property.

Carrying your Light before you move your Light, shut it down and disconnect all cables and cords connected to it. Using power cord Never force a connector into a port. Don't put the power cord into your tank when it is connected. When you Setup your Light please make sure that it locate power supply where it will not be exposed to any water or moisture.

Mount your power supply where it won't get wet. Include a "drip loop" - a tied loop of cord hanging down below the level of the electrical outlet. That way, if water happens to run down the cord from the tank, it will drip off onto the floor rather than into the outlet. Drip Loops should always be used to help prevent water from traveling along the cord and coming into contact with an electrical outlet. Drip loops must always be below the level of the outlet. If the plug or outlet does get wet, DO NOT TOUCH the cord.

Storing your Light If you are going to store your Light for an extended period of time, keep it in a cool location (ideally, 71° F or 22° C).

When cleaning the outside of your Light, first shut down your Light and unplug the power cord. Then use a damp, soft, lint-free cloth to clean the lamp exterior. Avoid getting moisture in any openings. Do not spray liquid directly on the lamp. Do not use aerosol sprays, solvents, or abrasives that might damage the finish.

MicMol and the Environment

MicMol recognizes its responsibility to minimize the environmental impact of its operations and products.



Warranty

MicMol warrants all MicMol products to be free from manufacturing defects for one year from the original purchase date when purchased through an authorized MicMol retailer. This warranty does not cover any damages caused by misuse, neglect, alterations or improper handling / transport / maintenance / installation. Physical damages are not covered by warranty. MicMol does not cover personal injury, personal loss, or other damages associated with the use of our products. In order to request warranty service, please email us at support@micmol.com. A purchase receipt is required for any warranty service. Products requiring warranty service must be returned to MicMol or authorized MicMol retailer. You are responsible for the cost of shipping a warranty claim to MicMol and any damages that may occur during transit. Once a returned product has been inspected, it will be repaired or exchanged at our discretion and returned to you. Thank you very much.

